



AB **ROLLER**[®] *Evolution*



OWNER'S MANUAL

WARRANTY
INFORMATION
INSIDE



Table of Contents

Important Safeguards	4
AbRoller® Evolution Set-Up Instructions	
Parts List and View	5
Assembly Steps	5-6
Exercising with the AbRoller® Evolution	
Ab Training	7
Upper Body Training	8-9
Adding Weights for Extra Resistance	9
Warranty Information	10



Introduction

Thank you for purchasing the AbRoller® Evolution... the total upper body trainer that helps you develop hard abs and get toned, muscular arms, shoulders and chest. The AbRoller® Evolution allows you to perform effective abdominal crunches while limiting stress and strain to your neck, head and shoulders. Now you can also add weights for even better results. Then turn over the AbRoller® Evolution for a serious upper body workout.

Before starting any exercise or conditioning program you should consult with your personal physician to see if you require a complete physical exam. This is especially important if you are over the age of 35, have never exercised before, are pregnant or suffer from any illness. Please read, understand and follow the important safeguards.

IMPORTANT SAFEGUARDS

CONSULT YOUR PHYSICIAN BEFORE BEGINNING ANY DIET OR EXERCISE PROGRAM

- Maximum user weight is 225 lbs.
- If at any time you feel faint, light headed or dizzy, please stop exercising immediately. You should also stop if you experience undue stress, pressure or pain at any time. See your doctor before continuing to workout.
- Please keep all children and pets away from the AbRoller® Evolution during use, as well as when the machine is unattended.
- Make sure that all bolts are tight prior to each day's use. Periodic maintenance is required on all exercise equipment in order for it to remain in good operating condition.
- Use the machine on a flat, level surface.
- **WARNING:** When turning over unit to use as an upper body trainer, make sure the Ab Roller Evolution is stable and secure and not placed on a moveable rug or carpet, or on a slippery or smooth floor. When using the unit as an upper body trainer, be sure the unit is secure and stable before placing all your weight on it.
- Wear proper clothing. Wear workout gear that allows free movement such as jogging and warm up suits, shorts, T-shirts or other clothing that fits correctly.
- Always follow the correct exercising procedure for the AbRoller® Evolution.
- Always choose the proper workout which best suits your physical strength and flexibility level.
- Follow your doctor's recommendations in developing your own personal fitness program.
- Know your limits and train within them. Always use common sense when exercising.

SAVE THESE INSTRUCTIONS.

SET-UP INSTRUCTIONS

Please note: You'll find assembly relatively easy.
All tools and parts necessary for assembly are included.

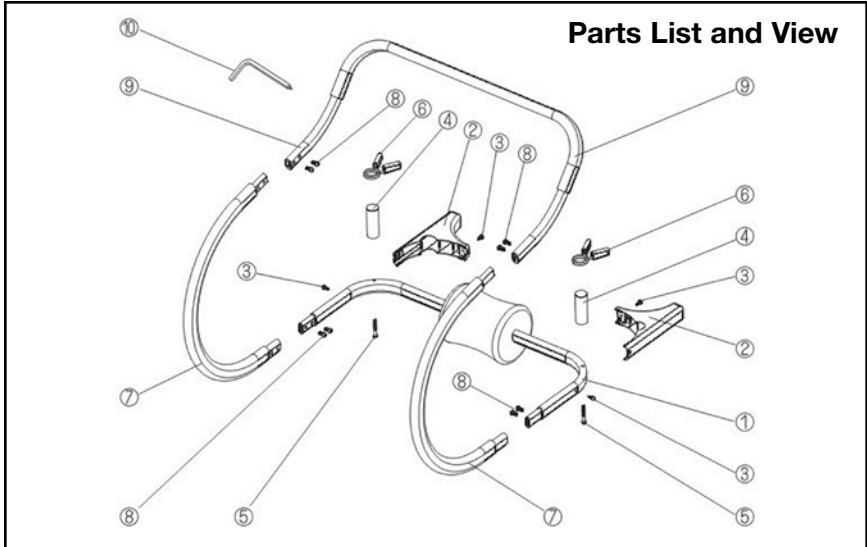

Parts List and View

No.	Part Name	Qty	No.	Part Name	Qty
01	Headrest Bar	1	06	Clips	2
02	Footpad	2	07	Arm/Side Bars	2
03	Screw	4	08	Short Screw	8
04	Weight Bar	2	09	Overhead Bar	1
05	Long Screw	2	10	Allen Wrench	1

ASSEMBLY STEPS

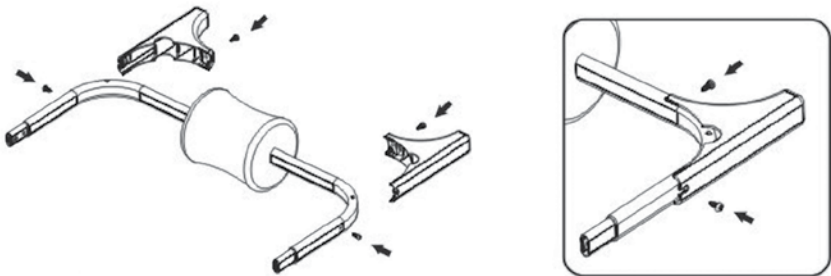

STEP 1: Attach Footpads (2) to the Headrest Bar (1).
Tighten securely with Screws (3).

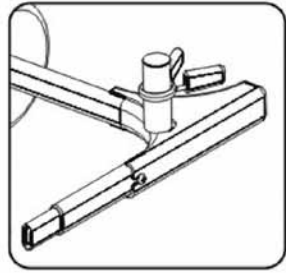
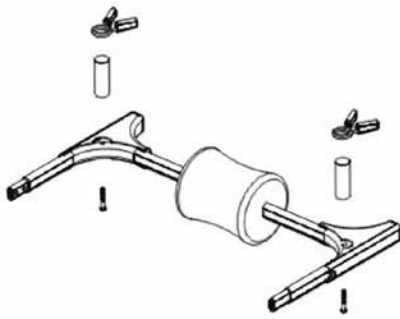

STEP 2: Attach Weight Bar (4) to the Headrest Bar (1) using the Long Screws (5) provided. Clips (6) are used to secure weights (not included) onto the Weight Bar (4).

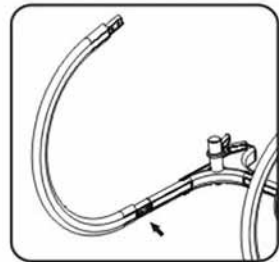
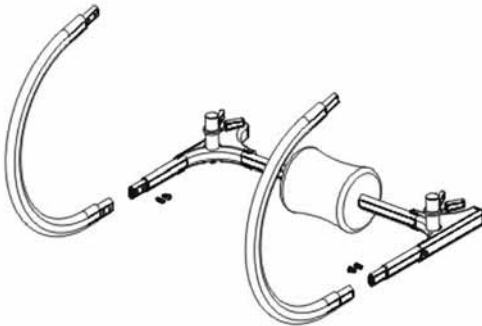

STEP 3: Attach Arm/Side Bars (7) to the Headrest Bar (1) using the Short Screws (8) provided.

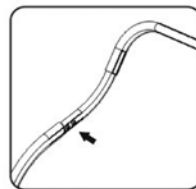
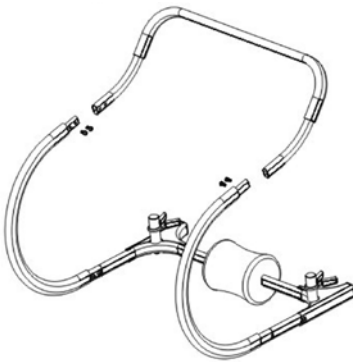

STEP 4: Attach Overhead Bar (9) to the Arm/Side Bars (7) using the Short Screws (8) provided.

AB TRAINING

Fig. 1



BASIC FORWARD CRUNCH:

Lie down with your hands on the frame, your knees bent, your feet planted on the floor, and your head resting against the head and neck support as shown in Figure 1.

While using your ab muscles to lift, raise your shoulders up about 45 degrees from the floor. Lower your shoulders back down as shown in Figure 2. Repeat.

(Try to use only your ab muscles to lift and minimize pushing forward with your hands and arms.)

Fig. 2



Fig. 3



OBLIQUE CRUNCH:

This exercise targets your oblique muscles (“love handles”). Lie down with your hands on the frame, your knees bent, your feet planted on the floor and your head resting against the head and neck support. Let your legs fall over to your right side as shown in Figure 3. While using

your ab muscles to lift, raise your shoulders up about 45 degrees from the floor. Lower your shoulders back down. Repeat. When complete, let your legs fall over to the left side and repeat exercise for other oblique.

Fig. 4



V-CRUNCH:

This exercise targets your lower abdominal muscles. Raise your legs straight up, keeping them together. While using your ab muscles to lift, raise your shoulders up about 45 degrees from the floor. Lower your shoulders back down as shown in Figure 4. Keep your legs straight up while performing the exercise. Repeat.

UPPER BODY TRAINING

WARNING: When turning over unit to use as an upper body trainer, make sure the AbRoller Evolution is stable and secure and not placed on a moveable rug or carpet, or on a slippery or smooth floor. When using the unit as an upper body trainer, be sure the unit is secure and stable before placing all your weight on it.

Fig. 1



DIPS:

This is an excellent exercise for your arms and shoulders. Start by turning the AbRoller Evolution over (as shown in Figure 1). Make sure unit is stable and not slipping on floor or wobbly. Facing away from the head rest, grasp the sides of the AbRoller Evolution, keep your feet together and extended in front of you. Most of your weight will be supported by your arms.

Slowly lower your body down towards the floor by bending your elbows, keeping the tension on your arms as you go down. Keep your elbows tucked along your sides, do not splay them out. Go down until your triceps are parallel to the ground. (as shown in Figure 2) Pause, and then push up to the starting position. Repeat.

Fig. 2



Fig. 3



STANDARD PUSH UPS:

This is an excellent exercise for your chest, shoulders, and arms. Start by turning the AbRoller Evolution over (as shown in Figure 3). Make sure unit is stable and not slipping on floor or wobbly. Facing the head rest, grasp the sides of the AbRoller Evolution, keep your feet together and extended behind you. Balance your weight between your palms and your toes.

Keeping your body straight, lower your body by bending your elbows. To perform a standard push up, go down until your chest almost touches your hands (as shown in Figure 4). Return to starting position, repeat.

Fig. 4

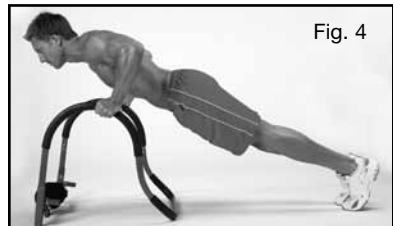

UPPER BODY TRAINING (cont.)

DEEP PUSH UPS:

To perform a deep push up, go down until your chest dips below your hands (as shown in Figure 5). Return to starting position, repeat.

Deep push ups are more effective than standard push ups because you can go down farther, challenging and stretching your muscles around the chest, shoulders and arms.

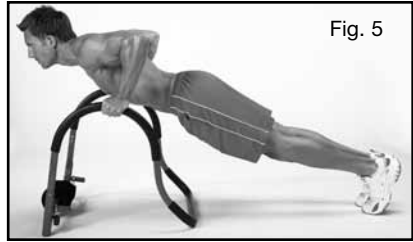

ADDING WEIGHTS FOR EXTRA RESISTANCE



Using Added Weight For Resistance

Studies show that resistance training helps to tone and build muscle and helps you lose fat. With the AbRoller® Evolution, you can use resistance training for your abs and waist by adding weights. There are 2 weight posts on the base of the AbRoller® Evolution for adding weights (weights not included).

CAUTION: Do not add more than 10 lbs. of weight in total to the posts (2 plates of 5 lbs. each or 4 plates of 2.5 lbs. each). Before adding any weight, ensure that you are able to perform the exercise with proper form without any additional weights.



Manufacturer's Limited Warranty

The manufacturer warrants that your AbRoller Evolution® is free of defects in materials and workmanship and will, at its option, repair or replace any defective AbRoller Evolution® that is returned to it. This warranty runs for sixty (60) days from the original date of purchase, and is valid only in accordance with the conditions set forth below:

1. Normal wear and tear are not covered by this warranty. This warranty applies to consumer use only, and is void when the product is used in a commercial or institutional setting.
2. The warranty extends only to the original consumer purchaser and is not transferable. In addition, proof of purchase must be demonstrated. This warranty is void if the product has been subject to accident, misuse, abuse, improper maintenance or repair, or unauthorized modification.
3. This limited warranty is the only written or express warranty given by the manufacturer. Any implied warranty of merchantability or fitness for a particular purpose on this product is limited in duration to the duration of this warranty. Some states do not allow limitations on how long an implied warranty lasts, so the above limitation may not apply to you.
4. Repair or replacement of the product (or, if repair or replacement is not feasible, a refund of the purchase price) is the exclusive remedy of the consumer under this warranty. The manufacturer shall not be liable for any incidental or consequential damages for breach of this warranty or any implied warranty on this product. Some states do not allow the exclusion or limitation of incidental or consequential damages, so the above limitation or exclusion may not apply to you.
5. This warranty gives you specific legal rights, and you may also have other rights which vary from state to state.

Procedure for Warranty Repairs or Replacement:

If warranty service is necessary, the original purchaser must pack the product securely and send it postage paid with a description of the defect, proof of purchase, and a check or money order for \$9.99 to cover return postage and handling to the following address: **AbRoller Evolution®, P.O. Box 3007, Wallingford, CT 06492.**



Thank you for purchasing the AbRoller® Evolution.

The logo features the letters 'AB' in a large, bold, red font. A red swoosh underline starts under the 'A' and extends under the 'B'. Below 'AB' is the word 'ROLLER' in a bold, white, sans-serif font with a registered trademark symbol. Underneath 'ROLLER' is the word 'Evolution' in a red, italicized, sans-serif font.

AB
ROLLER[®]
Evolution

Distributed by



© Tristar Products, Inc.
All rights reserved.

U.S. Patent # 5,577,987 and other Patents Pending.
U.S. Trademark Registration Number 3809909